

HDMCII VDSL2 LAN Extender Module (Extended Temp)

Use existing phone-grade wiring to support high-bandwidth Ethernet connections.



**Customer
Support
Information**

Order toll-free in the U.S.: Call 877-877-BBOX (outside U.S. call 724-746-5500)
FREE technical support 24 hours a day, 7 days a week: Call 724-746-5500 or fax
724-746-0746 • Mailing address: Black Box Corporation, 1000 Park Drive, Lawrence,
PA 15055-1018 • Web site: www.blackbox.com • E-mail: info@blackbox.com

FCC and Industry Canada RF Interference Statements

Class B Digital Device. This equipment has been tested and found to comply with the limits for a Class B computing device pursuant to Part 15 of the FCC Rules. These limits are designed to provide reasonable protection against harmful interference in a residential installation. However, there is no guarantee that interference will not occur in a particular installation. This equipment generates, uses, and can radiate radio frequency energy, and, if not installed and used in accordance with the instructions, may cause harmful interference to radio communications. If this equipment does cause harmful interference to radio or telephone reception, which can be determined by turning the equipment off and on, the user is encouraged to try to correct the interference by one of the following measures:

- Reorient or relocate the receiving antenna.
- Increase the separation between the equipment and receiver.
- Connect the equipment into an outlet on a circuit different from that to which the receiver is connected.
- Consult an experienced radio/TV technician for help.

CAUTION

Changes or modifications not expressly approved by the party responsible for compliance could void the user's authority to operate the equipment.

To meet FCC requirements, shielded cables and power cords are required to connect this device to a personal computer or other Class B certified device.

This digital apparatus does not exceed the Class B limits for radio noise emission from digital apparatus set out in the Radio Interference Regulation of Industry Canada.

Certifications

**Class 1 Laser product, Luokan 1 Laserlaite,
Laser Klasse 1, Appareil A' Laser de Classe**

European Directive 2002/96/EC (WEEE) requires that any equipment that bears this symbol on product or packaging must not be disposed of with unsorted municipal waste. This symbol indicates that the equipment should be disposed of separately from regular household waste. It is the consumer's responsibility to dispose of this and all equipment so marked through designated collection facilities appointed by government or local authorities. Following these steps through proper disposal and recycling will help prevent potential negative consequences to the environment and human health. For more detailed information about proper disposal, please contact local authorities, waste disposal services, or the point of purchase for this equipment.



Table of Contents

Part Numbers	5
1. Specifications	6
2. Overview: About the HDMCII VDSL2 LAN Extender Module (Extended Temp).....	7
3. Configuration	8
3.1 DIP Switch Settings.....	8
3.2 Host CO Module Configuration	9
3.3 Remote CPE Module Configuration	9
3.4 DATA Port Features	9
3.5 Auto Negotiation.....	10
3.6 Selective Advertising.....	10
3.7 SNMP Management.....	10
3.8 LINK Quality	11
3.9 Forcing Duplex Mode	11
3.10 Forcing the Data Port Speed.....	12
3.11 Flow Control	12
4. Install the HDMCII VDSL2 LAN Extender Module (Extended Temp) ..	13
5. Operation.....	14
5.1 LED Operation.....	14
5.2 Maximum Bandwidth HDMCII VDSL2 LAN Extender Module (Extended Temp) Link LEDs	15
5.3 RJ-45 Data Port Pinout (MDI)	16
5.4 RJ-11 Port Pinout.....	16
5.5 Link Fault Pass-Through	17
5.6 Fault Loopback (FL)	17
6. Troubleshooting.....	18
7. Contacting Black Box	19
8. Fiber Optic Cleaning Guidelines	20
9. Electrostatic Discharge Precautions	21

Part Numbers

Part Number	Description
LMC5601C-VDSL2	HDMCII VDSL2 LAN Extender Module (Extended Temp)

1. Specifications

DC Input	662 mA @ 5V
Operating Temperature	-40°F to +185°F (-40°C to +85°C)
Storage Temperature	-67°F to +257°F (-55°C to +125°C)
Humidity	5% to 95% (non-condensing); 0 to 10,000 ft. altitude
Dimensions	Single Slot SNMP Manageable Modules

2. Overview: About the HDMCII VDSL2 LAN Extender Module (Extended Temp)

HDMCII VDSL2 LAN Extender Module (Extended Temp) enables LAN and Campus network managers, and service providers, to use an existing phone-grade wiring to support high bandwidth Ethernet connections. Industry standard 2Base-TL provisions symmetric data delivery over the outside plant defined by IEEE802.3ah. 10Pass-TS transport is designed to meet short-range, high data rate requirements over standard copper wire defined by IEEE802.3ah for inside a plant environment. They can achieve this by using Ethernet over VDSL where the 100m distance limitation of twisted pair data cabling is no longer a challenge.

Designed with VDSL2 (second generation Very high-bit-rate Digital Subscriber Line) technology, the Black Box Ethernet-to-VDSL2 converter allows the transmission of data over a single pair of sub-standard CAT3 and other telephone cabling to achieve substantially longer distances. As a media and protocol converter, the HDMCII VDSL2 LAN Extender Module (Extended Temp) includes the ability to transfer data both symmetrically and asymmetrically to meet the customer's needs. In either mode, the VDSL2 port automatically adjusts to an operating point that maximizes the Full-Duplex bandwidth capability of the line for true plug-and-play operation.

Two HDMCII VDSL2 LAN Extender Module (Extended Temp) media converters are configured as pairs for each link. One is configured as a Host (Central Office (CO)) HDMCII VDSL2 LAN Extender Module (Extended Temp) and is typically deployed at the CO close to network management systems. The other is configured as a Remote (Customer Premise (CPE)) HDMCII VDSL2 LAN Extender Module (Extended Temp) and is deployed at the CPE. Full SNMP remote line management is provided through a Black Box managed chassis, providing remote notification of line fault conditions.

HDMCII VDSL2 LAN Extender Module (Extended Temp) includes:

- One VDSL port with an RJ-11 connector (VDSL)
- One 10/100BaseT Ethernet port with an RJ-45 connector (DATA Port)

3. Configuration

HDMCII VDSL2 LAN Extender Module (Extended Temp) includes various user-configurable features. These features are selectable by using DIP Switches and software. The following sections describe the DIP Switches for the Host CO and Remote CPE module configuration.

3.1 DIP Switch Settings

The DIP Switches allow the user to configure most of the module features before installing the unit. These also enable the Host to Remote management channel used with SNMP management. Refer to the following diagram and setting table for DIP Switch selection information.

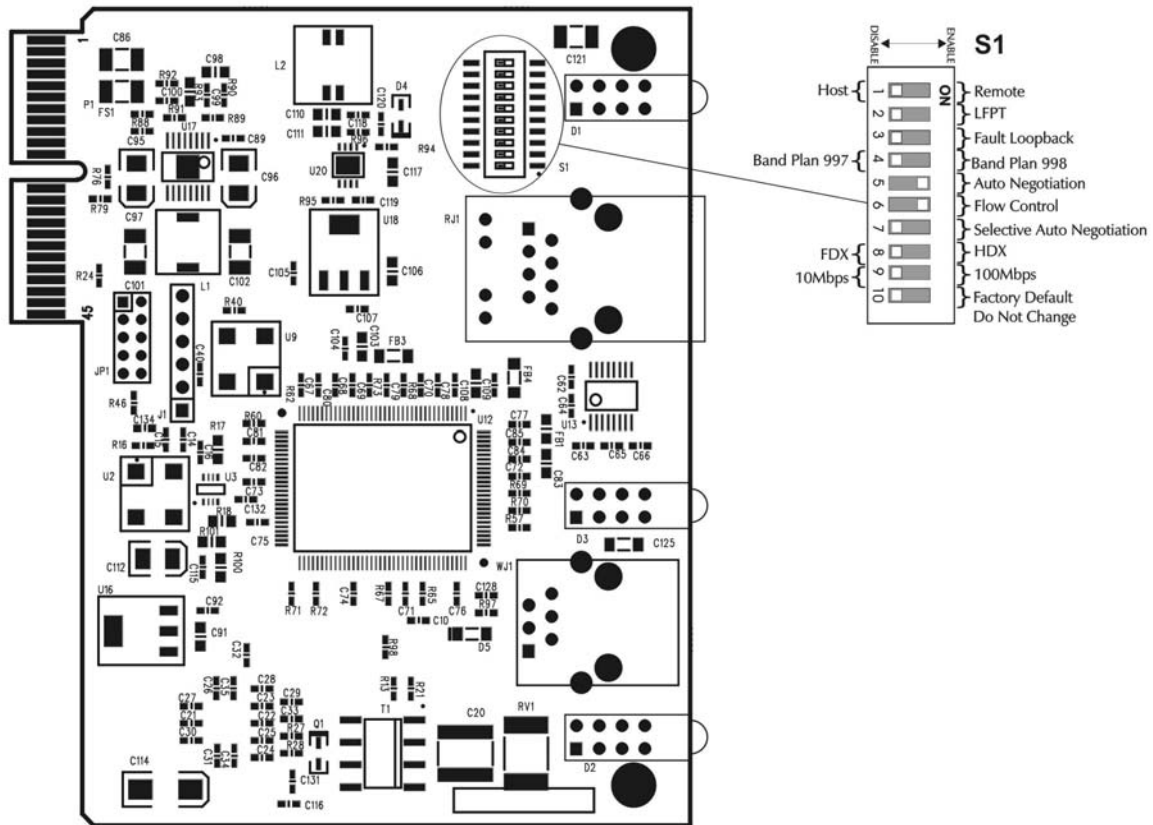

Switch #	Feature	Function	Default
1	HOST	HOST=OFF / Remote=ON	OFF
2	LFPT	On= Link Fault Pass-Through Enabled	OFF
3	FL	ON= Fault Loopback Enabled	OFF
4	Band Plan	On= Asymmetric 998 with ISDN Off= Symmetric 997 with ISDN	OFF
5	AN	On= Auto Negotiation ON	ON
6	Flow Control	On= Flow Control ON	ON
7	Selective AN	On= Selectively advertises Speed Duplex if AN is enabled	OFF
8	Duplex	OFF= Full Duplex / ON= Half Duplex	OFF
9	Speed	On= 100Mbps / Off= 10Mbps	OFF
10	Factory Default	Factory Default: Do not Use	OFF

These features are described in more detail in the following sections.

3.2 Host CO Module Configuration

To allow the HOST (CO) HDMCII VDSL2 LAN Extender Module (Extended Temp) to manage the remotely connected (CPE) HDMCII VDSL2 LAN Extender Module (Extended Temp) unit, set DIP Switch #1 to the OFF position (default setting). This selection can only be performed manually and cannot be overridden by software settings.

A Host configured CO HDMCII VDSL2 LAN Extender Module (Extended Temp) must be installed in a managed chassis to allow SNMP management through iView². The High-Density Media Converter System II chassis series, available in 3, 6 and 20 slots with an optional SNMP Management Module, is recommended. Please refer to the section SNMP Management.

3.3 Remote CPE Module Configuration

To configure a CPE HDMCII VDSL2 LAN Extender Module (Extended Temp) as a Remote CPE, set DIP Switch #1 to the ON position (OFF is the default setting).

A Remote CPE configured HDMCII VDSL2 LAN Extender Module (Extended Temp) can be installed in an unmanaged chassis. These chassis can include Density Media Converter System II chassis with the optional SNMP agent management module removed.

3.4 DATA Port Features

The 10/100BaseT DATA port on the HDMCII VDSL2 LAN Extender Module (Extended Temp) Auto Negotiates for speed and duplex mode. These modules also provide the option of manually setting the speed and duplex mode if the connected devices do not have the ability to Auto Negotiate, or

when Auto Negotiation is not desired by configuring using DIP Switches #8 and #9.

3.5 Auto Negotiation

The HDMCII VDSL2 LAN Extender Module (Extended Temp) ships from the factory with Auto Negotiation enabled on the DATA port. In this mode, the DATA port negotiates for speed and duplex (i.e., the module detects 10 Mbps Full-Duplex, 10 Mbps Half-Duplex, 100 Mbps Full-Duplex or 100 Mbps Half-Duplex with Flow Control). Configure Auto Negotiation on an HDMCII VDSL2 LAN Extender Module (Extended Temp) by adjusting the DIP Switch #5 (for unmanaged modules) or via the management software (for managed modules).

3.6 Selective Advertising

Selective Advertising (DIP Switch #7), when used in combination with Auto Negotiation, advertises only the configured speed and duplex mode for the DATA port. If Selective Advertising and Auto Negotiation are both switched ON, the DATA port's speed (10 or 100 Mbps) and Duplex mode (FDX or HDX) are selectively advertised individually per switch setting #5 and #7.

NOTE
<i>If you require a specific speed and/or duplex mode, Black Box recommends using Selective Advertising rather than Force Mode when connecting the modules to devices that can ONLY Auto Negotiate. Selective Advertising is NOT an option when you disable Auto Negotiation.</i>

3.7 SNMP Management

Once the DIP Switches have been set on each module to enable one to be a Host and the other a Remote, the Host can be installed in a High-Density Media Converter System II chassis that includes an installed SNMP Management Module. The Host VDSL2 module then manages the Remote VDSL2 module via the SNMP software iView².

Traps can also be set in the iView² software. A Trap will be generated on any Loss of Signal (LOS); but more importantly, the end user can set a **VDSL Quality Level** that will generate a trap if the line fails below the assigned level.



3.8 LINK Quality

Link Quality is defined by 4 values: 8,4,2,1. The four green LEDs form a binary code indicating the maximum bandwidth the VDSL line can support. The appropriate LED will light once the line quality is dynamically detected. This represents the maximum Downstream data rate (Kbps) the line can support based upon line noise and line length. The Upstream rate will be less based on the Base Plan used.

3.9 Forcing Duplex Mode

The DATA port can be manually configured on the HDMCII VDSL2 LAN Extender Module (Extended Temp) for Half- or Full-Duplex operation. Before manually setting the duplex mode, disable Auto Negotiation (Set DIP Switch #5 to OFF).

- Full-Duplex for the DATA port is configured by setting DIP Switch #8 to the OFF position (default).
- Half-Duplex for the DATA port is configured by setting DIP Switch #8 to the ON position.

3.10 Forcing the Data Port Speed

The DATA port can be manually configured on HDMCII VDSL2 LAN Extender Module (Extended Temp) for 10 Mbps or 100 Mbps operation. Before manually setting the speed, disable Auto Negotiation (Set DIP Switch #5 to the OFF position.)

- 10 Mbps for the DATA port is configured by setting DIP Switch #9 to the OFF position (default).
- Configure the DATA port for 100 Mbps operation by setting DIP Switch #9 to the ON position.

3.11 Flow Control

Flow Control is used as back pressure on the 10/100BaseT DATA interface to avoid dropping packets during VDSL link congestion. Full-Duplex Flow Control will be advertised only when the module is set to Full-Duplex Mode. For Full-Duplex Flow Control to operate, the link partner (connected devices) must also support Flow Control. Half-Duplex Flow Control does not advertise but provides a hardware based backpressure on the Ethernet line to limit traffic.

Flow Control should be considered whenever the VDSL line provides less bandwidth than the DATA port. If the Ethernet line is attempting to send more data than the VDSL2 line can support, the Overflow (OVF) LED will come ON indicating frames are being discarded due to congestion.

Overflow activity will be less if Flow Control is enabled. Flow Control or Pause will limit the number of dropped Ethernet frames by reducing the congestion, therefore minimizing the overflow of the VDSL line.

Configure the DATA port on the HDMCII VDSL2 LAN Extender Module (Extended Temp) for Flow Control by setting DIP Switch #6 to the ON position.

4. Install the HDMCII VDSL2 LAN Extender Module (Extended Temp)

Before installing an HDMCII VDSL2 LAN Extender Module (Extended Temp), set the options using the DIP Switches (refer to the DIP Switch Settings section for more information).

Install HDMCII VDSL2 LAN Extender Module (Extended Temp) in any Black Box High-Density Media Converter System II chassis. Each module requires one slot in the chassis; always use HDMCII VDSL2 LAN Extender Module (Extended Temp) in pairs with the Host module at the CO and the Remote module at the CPE.

To install a module, remove the blank brackets (if present) covering the slots where you will install the module by removing the screws on the outside edges of the bracket. Slide the module into the chassis, via the card guides, until the module is seated securely in the connector. Secure the module to the chassis by tightening the captive screw. Save any blanks removed during installation for future use.

Remote CPE modules can be installed in a managed or unmanaged chassis. Remote CPE modules can only be managed from the connected Host CO HDMCII VDSL2 LAN Extender Module (Extended Temp) installed in a managed chassis. The user should always set remote DIP Switches to provide a base value under VDSL line fault conditions. In addition, some features may not be software configurable on the remote unit. After setting the DIP Switches, install the HDMCII VDSL2 LAN Extender Module (Extended Temp). Once the VDSL line is established, the line can be monitored and configured through the iView² management software available for download at

<ftp://ftp.blackbox.com/anonymous/lan/Managed%20Media%20Converters/LMC5200a/>.

5. Operation

5.1 LED Operation

Each module features diagnostic LEDs that provide information on features and ports.

LED	Function
VDSL2	
RAI	The Remote Alarm Indication LED is YELLOW when the unit at the far end of the Unit has an alarm
FL	Fault Loopback will be ON GREEN if this function is enabled and BLINK if it is actively inhibiting the Ethernet port due to a LOS of the VDSL line
LOS	The LOS LED is RED when the VDSL port is down.
ER	The ERROR LED will Blink YELLOW when the VDSL line receives a symbol error. ON if the VDSL bandwidth falls below the user defined level.
LINK QUALITY	
8-4-2-1	These 4 GREEN LEDs form a binary code indicating the MAX bandwidth the VDSL line can support.
DATA	
OVF	Overflow LED will Blink YELLOW when frames are lost due to congestion on the VDSL line.
LFPT	Link Fault Pass-Through will be ON GREEN if this function is enabled and BLINK if it is actively inhibiting the Ethernet port due to a LOS of the far end TX line.
LOS	The LOS LED is RED when the DATA port is down.
ER	The ER LED is YELLOW when the DATA port receives an error.

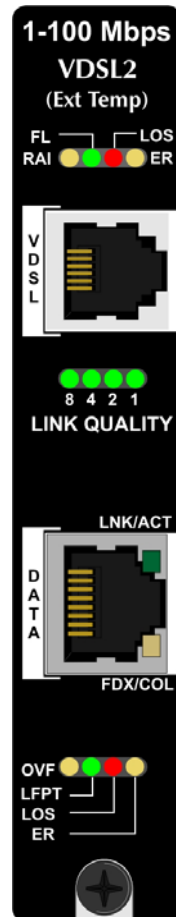

The VDSL2 will generate a Trap (when enabled in iView²) whenever a Loss of Signal (LOS) occurs. In addition, the end user can set a VDSL Quality Level that will generate a Trap if the line fails below that set level.

5.2 Maximum Bandwidth HDMCII VDSL2 LAN Extender Module (Extended Temp) Link LEDs

The standard single pair HDMCII VDSL2 LAN Extender Module (Extended Temp) unit will provide the following Rate/Reach performance under the best conditions and still maintain a BER > 10⁻⁹ performance over single pair 24 AWG (0.5mm) twisted wire.

HDMCII VDSL2 LAN Extender Module (Extended Temp) Rate/Reach

Distance (feet)	Link 8	Link 4	Link 2	Link 1	BW 997		BW 998	
					<Mbps (down)	<Mbps (up)	<Mbps (down)	<Mbps (up)
<950	1	1	1	1	93	76	99	50
950	1	1	1	1	74	64	90	45
1200	1	1	0	1	64	56	81	39
1500	1	0	1	1	52	47	70	30
1800	1	0	0	1	43	35	59	22
2300	0	1	1	1	33	20	45	12
3200	0	1	0	1	24	9	29	5
4700	0	0	1	1	17	1	18	1
5500	0	0	0	1	11	1	11	1
>5500	0	0	0	0	no Link	no Link	no Link	no Link

The unit will automatically adjust to reach the best bandwidth performance for the physical line it is connected to. The associated LED display will indicate the Bandwidth performance the unit is running at any given time.

This is not the bandwidth that is being transmitted but the bandwidth capability of the line. The Bandwidth number is based on "VDSL User Payload" and includes the VDSL Frame overhead. For Band Plan 998, this LED display will indicate the MAX down stream rate to the Remote unit.

Band Plan 997 will provide the greatest symmetrical bandwidth the line can support. The end user can also select Band Plan 998 for asymmetric operation, to provide better downstream performance. Either plan will automatically adjust for the greatest bandwidth transport. The HDMCII VDSL2 LAN Extender Module will automatically seek the best operating condition for the physical line it is connected to.

NOTE

The RANGE is only an approximation based on a typical line in a normal noise environment. Actual distances will vary depending on the condition of the physical line in use.

When the Ethernet port is connected at 10BaseT, the VDSL2 line will be limited to 10 Mbps operation and will indicate a RANGE of 5500 feet or less for all length lines.

5.3 RJ-45 Data Port Pinout (MDI)

The following table lists the pin configuration for the RJ-45 Data connector.

Pin	Signal
1	Transmit+
2	Transmit-
3	Receive+
4	No Connection
5	No Connection
6	Receive-
7	No Connection
8	No Connection

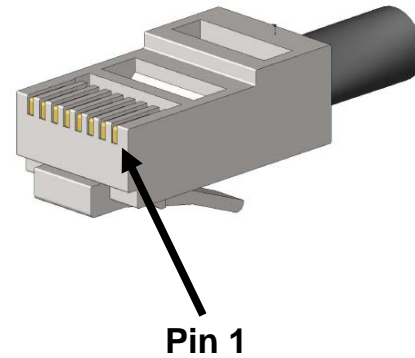

5.4 RJ-11 Port Pinout

VDSL ports are supported on RJ-11 (pin 3,4) connectors.

Pin	Signal
1	
2	
3	Ring (VDSL)
4	Tip (VDSL)
5	
6	

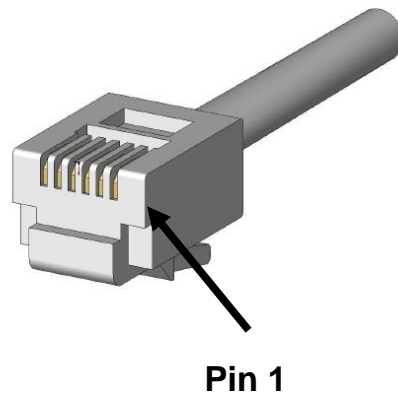

5.5 Link Fault Pass-Through

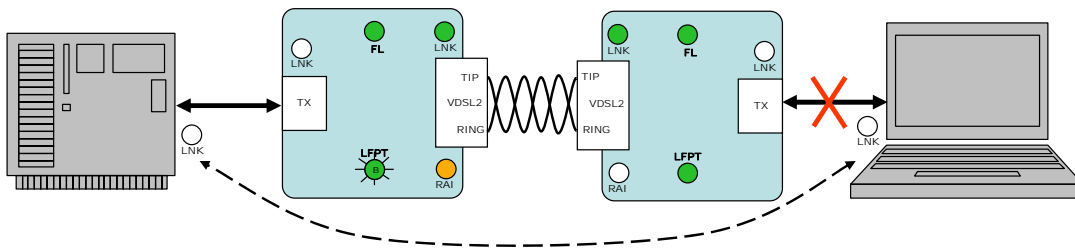

When a 10/100BaseT port is lost, the unit sends a fault signal (RAI) to the VDSL line. If the LFPT function is enabled at the Far End VDSL port receiving this fault indication, the far end unit will drop the link on the 10/100BaseT port and BLINK the LFPT LED. This function must be enabled at both ends of the VDSL line for this to function in both directions. The LFPT function is only active in one direction at a time and is indicated by the flashing LED. As such, clearing the far end fault may uncover a fault at the local end.

5.6 Fault Loopback (FL)

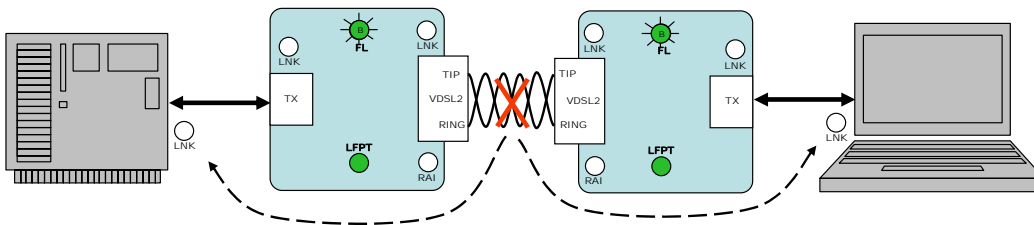

The Fault Loopback (FL) function will force the 10/100BaseT port to drop link if the VDSL line has lost link. If FL is enabled the LED will be ON GREEN and if this function is actively inhibiting the Ethernet port this LED will BLINK.

6. Troubleshooting

The most common failure of a VDSL line is its slow degradation over time due to aging of the line or increased line noise as additional service is added to the same Line bundle. To help detect this degradation over time, the unit provides a user-defined Minimum Quality Level. Once this level is reached, the unit will send an SNMP TRAP indication for low line quality. This can be used to provide an advanced notice to the customer of a potential problem BEFORE a loss of service is detected by the customer.

7. Contacting Black Box

Black Box Customer Service

Order toll-free in the U.S.: Call 877-877-BBOX
(outside U.S. call 724-746-5500)

Free technical support, 24 hours a day, 7 days a week.
Call: 724-746-5500 or Fax: 724-746-0746

Mail order: Black Box Corporation
1000 Park Drive, Lawrence, PA 15055-1018

Web site: www.blackbox.com

E-mail: info@blackbox.com

8. Fiber Optic Cleaning Guidelines

Fiber Optic transmitters and receivers are extremely susceptible to contamination by particles of dirt or dust, which can obstruct the optic path and cause performance degradation. Good system performance requires clean optics and connector ferrules.

1. Use fiber patch cords (or connectors, if you terminate your own fiber) only from a reputable supplier; low-quality components can cause many hard-to-diagnose problems in an installation.
2. Dust caps are installed at Black Box to ensure factory-clean optical devices. These protective caps should not be removed until the moment of connecting the fiber cable to the device. If you need to disconnect the fiber device, reinstall the protective dust caps.
3. Store spare caps in a dust-free environment such as a sealed plastic bag or box so that when reinstalled they do not introduce any contamination to the optics.
4. If you suspect that the optics have been contaminated, alternate between blasting with clean, dry, compressed air and flushing with methanol to remove particles of dirt.

9. Electrostatic Discharge Precautions

Electrostatic discharge (ESD) can cause damage to any product, add-in modules or stand alone units, containing electronic components. Always observe the following precautions when installing or handling these kinds of products.

1. Do not remove unit from its protective packaging until ready to install.
2. Wear an ESD wrist grounding strap before handling any module or component. If the wrist strap is not available, maintain grounded contact with the system unit throughout any procedure requiring ESD protection.
3. Hold the units by the edges; do not touch the electronic components or gold connectors.
4. After removal, always place the boards on a grounded, static-free surface, ESD pad or in a proper ESD bag. Do not slide the modules or stand alone units over any surface.



WARNING! Integrated circuits and fiber optic components are extremely susceptible to electrostatic discharge damage. Do not handle these components directly unless you are a qualified service technician and use tools and techniques that conform to accepted industry practices.

NOTES

Black Box Tech Support: FREE! Live. 24/7.

Tech support the
way it should be.



Great tech support is just 30 seconds away at
724-746-5500 or blackbox.com.



About Black Box

Black Box Network Services is your source for more than 118,000 networking and infrastructure products. You'll find everything from cabinets and racks and power and surge protection products to media converters and Ethernet switches all supported by free, live 24/7 Tech support available in 30 seconds or less.

© Copyright 2010. Black Box Corporation. All rights reserved. Printed in U.S.A. Black Box® and the Double Diamond logo are registered trademarks of BB Technologies, Inc. Double Diamond™ is a trademark of BB Technologies, Inc. Any third-party trademarks appearing in this publication are acknowledged to be the property of their respective owners.

LMC5601C-VDSL2 Rev. 1

51-80970BB-00 Rev. A0

724-746-5500 | blackbox.com